

FLUSH MOUNTED LED CABIN LIGHT

Naval Flush Mounted Cabine Light with Diamond Structure Polycarbonate Diffuser. Conforms to IP22. Available with 20 Watt LED Module.

IP 22

Features

Housing & Cover : CRCA fabrication body with Zink Yellow Passivation as per DF STAN 03-20 and RAL 9010 epoxy powder coated surface finish.(can be customized on requirement)
-CRCA Thk : 1mm

Optics

Diamond Structure Polycarbonate diffuser.

Installation

Flush Mounted

Control gear: Control gear unit consists of constant current Power Supply and mains connector with Loopin Loopout facility.

Applications

For Cabin Room Illumination.

Mains Supply Voltage : 110...230 Volt AC Single Phase & 24 Volt DC

Product Photo



Product Dimensions

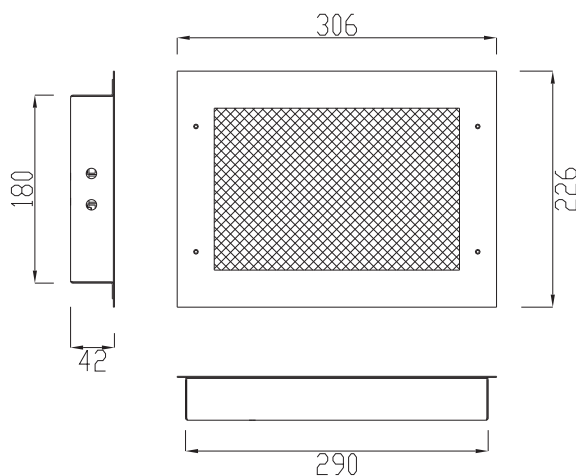

How To Order This Product

Catalogue Number	LED Type	Dimensions (mm)			Electrical Paramters		Accessories			
		A	B	C	Input Voltage	Mains Current (Amp)	Power Supply	Capacitor	Starter	Lamp Holder
MME-COM-07	20W LED	250	135	39	110...230 V AC	0.350	20W, 0.350A, 24V	NA	NA	NA
MME-COM-07-DC	20W LED	250	135	39	24 V DC	0.350	20W, 0.350A, 24V	NA	NA	NA

