

FLUSH MOUNTED CABIN LIGHT

Naval Flush mounted cabin light with Diamond Structure Diffuser. Conforms to IP22. Available with 2x20Watt Retrofit ES27 base Lamps.

IP 22

Features

Housing & Cover : CRCA fabrication body with Zink Yellow Passivation as per DF STAN 03-20 and RAL 9010 epoxy powder coated surface finish.(can be customised on requirement)
-Quick release Quarter turn Fasteners arrangement for quick maintenance
-CRCA Thk : 1mm

Optics

-3mm Diamond Structure Diffuser.
-Inside Reflector is made of full Specular High Purity Aluminium

Installation

Flush mounted.

Applications

For Cabin Illumination.

Control gear: Control gear unit consists of Special design ES27 Base Porcelain material Lamp Holders for Lamp fitment and Mains Connector with Loopin Loopout facility.

Mains Supply Voltage : 220...240 Volt AC Singal Phase
50 Hz

Product Photo



Product Dimensions

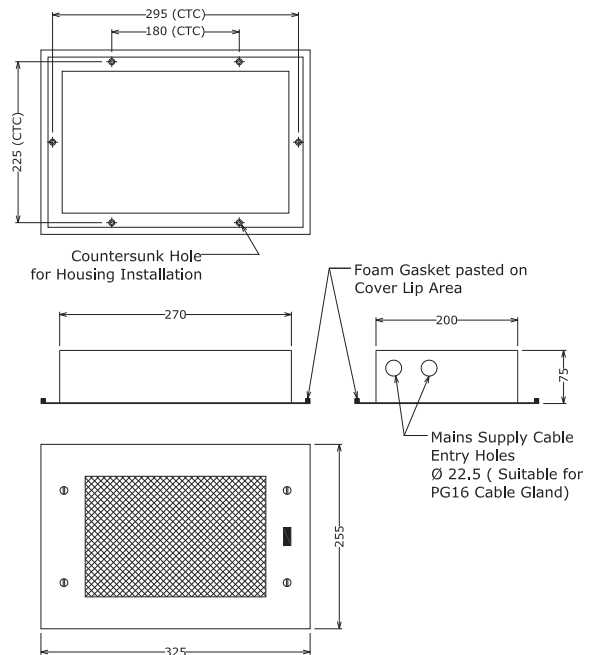

How To Order This Product

Catalogue Number	Lamp Type	Dimensions (mm)			Electrical Paramters		Accessories			
		A	B	C	Volt (V _{AC})	Mains Current (Amp)	Ballast	Capacitor	Starter	Lamp Holder
MME-COM-09/ES27	2x20 Watt Retrofit Es27 Base	325	255	75	220..240V 50 Hz	0.16	NA	NA	NA	Es27

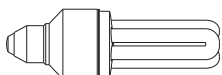

RETRO FIT ES27 BASE LAMP